



## Lockers + Storage Range 2023



# Contents

<b>Lockers</b>	<b>04-17</b>	<b>Technical Guide</b>	<b>30-31</b>
Secure it full height	09	Secure it dimensions	30
Secure it three quarter height	14	Secure it features	31
Secure it half height	17	Secure it options	31
<b>Storage</b>	<b>18-27</b>	<b>Materials</b>	<b>32-34</b>
Storewell Open	21	E0 Laminate - Secure it	32
Storewell Mini Tote	21	Compact Laminate - Secure it	33
Storewell Mixed Tote	21	Naturals - Secure it	33
Storewell Cupboard	21	E0 Laminate	34
Tote Mini	21	Laminated Plywood	34
Tote Maxi	21	Birch Plywood	34
Fusion Tote	22		
Fusion Drawer	22	<b>Support</b>	<b>35</b>
Fusion Wembley	22	Shipping	35
Fusion Bookcase	22	Furniture Warranty	35
Kube Browser	25	Returns + Exchanges	35
Rubix Browser	25		
Rubix Book Tower	25		
Inform Shelving System	26		

## What sets us apart



### Latest Designs

Every piece from our collections are innovatively designed and work together allowing you to mix, match, stack and scale to create a custom, flexible solution to suit your needs.



### Customisable

Our products can be supplied standard or customisable to your specification. Available in a wide array of finish options, quality is guaranteed with our lengthy warranties and ongoing product support.



### Durable

Our primary consideration is longevity of usefulness. Our products are typically of a heavier construction than the market benchmark which mitigates the need for replacement and disposal.



### Sustainable

We are committed to reducing our carbon footprint. We champion continuous improvement in our recycling techniques and work to improve efficiencies in the usage of finite resources.



### Great Value

Being vertically integrated allows us to set our prices below the competition so you can do more while spending less without compromising on quality, design or finish choices.



### On-Time Delivery

In our extensive warehouse we house our most popular furniture products that can be quick shipped within 48 hours. For larger projects we offer staged installation to meet your build schedule.

## How we work

### Consult + Plan

At VE Furniture we believe that the success of any project starts with a complete understanding of requirements, budgets and anticipated outcomes. This may include a site inspection and layout.

### Design + Order

Once the requirements have been validated we'll design and manufacture furniture to your specification and time frame with regular updates on progress and delivery timeframes.

### Deliver + Install

Goods will be delivered via the fleet of VE trucks at a time that's convenient. If desired we can even pre-assemble + place your furniture, and even remove any rubbish to provide you with our full white glove service.

### Care + Support

Once your furniture has been in place and utilised we'll follow up to ensure you're completely satisfied with the products and services supplied and will promptly resolve any concerns in the unlikely event of an issue.



# Lockers.

Secure storage for personal belongings,  
with easy access in a range of sizes,  
ideal for schools, offices and gyms.





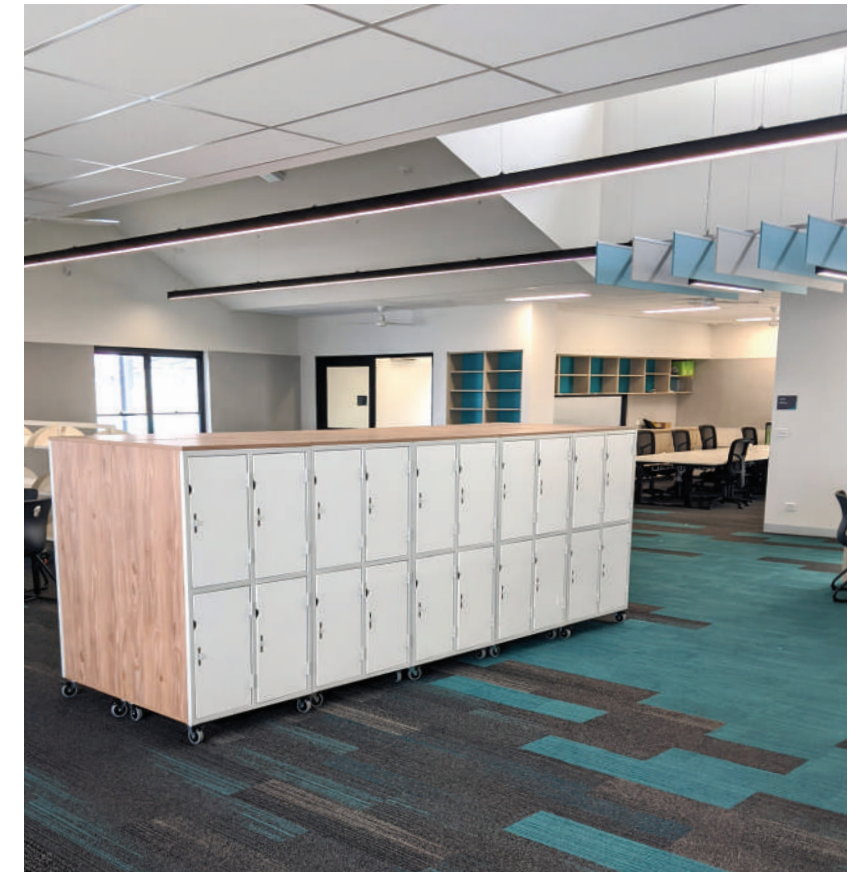

This Page: Secure it mobile (SEC020)

Opposite Page: Secure it Triple Bay (SEC009)



# Lockers



## Secure it FS1 Locker

Ideal for small spaces or offices, our Secure it Single Lockers are ideal for personal items. Includes shelf and coat hook.

**Model:** SEC001

**W375 x D580 x H1860**



## Secure it FS2 Locker

Ideal for small spaces or offices, our Secure it Single Lockers are ideal for personal items. Includes shelf and coat hook.

**Model:** SEC002

**W375 x D580 x H1860**



## Secure it FS3 Locker

Ideal for small spaces or offices, our Secure it Single Lockers are ideal for the secure storage of personal items.

**Model:** SEC003

**W375 x D580 x H1860**



# Lockers

## Secure it FD2 Locker

The Secure it Double Bay Lockers are conveniently size for school bags and personal belongings in school settings.

Model: SEC004

W725 x D580 x H1860



## Secure it FD4 Locker

The Secure it Double Bay Lockers are conveniently size for school bags and personal belongings in school settings.

Model: SEC005

W725 x D580 x H1860



## Secure it FD6 Locker

The Secure it Double Bay Lockers are conveniently size for school bags and personal belongings in school settings.

Model: SEC006

W725 x D580 x H1860





# Lockers



## Secure it FT3 Locker

Ideal for school offices and staff rooms, the Secure it triple bay lockers securely holds belongings. Shelf and coat hook.

**Model:** SEC007

**W1075 x D580 x H1860**



## Secure it FT6 Locker

Ideal for school breezeways and commons rooms, the Secure it triple bay lockers comfortably hold school bags.

**Model:** SEC008

**W1075 x D580 x H1860**



## Secure it FT9 Locker

Commons rooms, breezeways and gyms are the perfect setting for our Secure it large triple bay lockers.

**Model:** SEC009

**W1075 x D580 x H1860**



# Lockers



## Secure it QS1 Locker

The Secure it 3/4 height is a convenient compact size whilst still providing generous storage for personal belongings.

**Model:** SEC010

**W375 x D580 x H1270**



## Secure it QS2 Locker

The compact Secure it 3/4 height suits staff rooms and offices with two doors per bay for personal storage.

**Model:** SEC011

**W375 x D580 x H1270**



## Secure it QD2 Locker

The Secure it 3/4 height is a convenient compact size providing generous storage for personal belongings.

**Model:** SEC012

**W725 x D580 x H1270**



## Secure it QD4 Locker

The Secure it 3/4 height is ideal for use in classrooms, staffrooms and offices, providing storage for 4.

**Model:** SEC013

**W725 x D580 x H1270**



## Secure it QT3 Locker

The Secure it 3/4 height is a convenient size whilst still offering ample storage for belongings.

**Model:** SEC014

**W1075 x D580 x H1270**



## Secure it QT6 Locker

The Secure it 3/4 height provides ample storage for 6 without impeding sight lines in your space.

**Model:** SEC015

**W1075 x D580 x H1270**







# Lockers



### Secure it HS1 Locker

This half height locker is perfect for personal offices, as a first aid cupboard and for other individual storage needs.

**Model:** SEC016

**W375 x D580 x H970**



### Secure it HD2 Locker

Compact and light, the half height lockers are big on storage and small on space. Two convenient bays.

**Model:** SEC017

**W725 x D580 x H970**



### Secure it HT3 Locker

Half height lockers can be used in the centre of a room providing a usable top surface and open space feel.

**Model:** SEC018

**W1075 x D580 x H970**



### Secure it HQ4 Locker

At half the height of our full height lockers, these compact lockers provide convenient storage. Ideal as a room divider.

**Model:** SEC019

**W1075 x D580 x H970**



### Secure it MD4 Locker

The Secure it Mobile Locker offers convenient mobile storage where you need it to be. 4 door access.

**Model:** SEC020

**W810 x D500 x H1075**



### Secure it MQ8 Locker

The Secure it Mobile Locker is ideal for use anywhere you need to store belongings. Each door has its own access.

**Model:** SEC021

**W1600 x D500 x H1075**



# Storage.

Functional storage solutions for all your resources, materials and books, with the flexibility to change it up.





# Storage



### Storewell 8 Bay Open Storage

The ever practical Storewell 8 Bay Open Storage holds everything from bags to books and everything inbetween.  
**Model:** STO007

W1593 x D450 x H854



### Storewell 8 Bay Tote Storage

This convenient unit is the ideal cubby for lunch boxes and and take home materials.

**Model:** STO007 + STO011-KIT4

W1593 x D450 x H854



### Storewell 8 Bay Tote Storage

Keep your learning space organised with the Storewell 8 Bay Tote Storage unit. There's space for everything!

**Model:** STO007 + STO010-KIT3 + STO011-KIT4

W1593 x D450 x H854



### Storewell 8 Bay Cupboard Storage

With a generous sized storage cupboard this unit blends display with storage. Optional locks available.

**Model:** STO007 + STO012-KIT5

W1593 x D450 x H854



### Tote Mini Storage Box

The perfect size for need-it-now papers, learning materials and accessories.

**Model:** TOT001

W420 x D365 x H115

### Tote Maxi Storage Box

The perfect size for building blocks, art supplies and bulky toys and games.

**Model:** TOT002

W420 x D365 x H270



# Storage



## Fusion 20 Tote Storage Unit

The Fusion Storage Unit is perfect for storing and organising resources and loose items, with two convenient shelves.

Model: FUS002

W1200 x D900 x H904



## Fusion 30 Tote Storage Unit

The Fusion Storage Unit is perfect for storing and organising resources and loose items for ease of accessibility.

Model: FUS005

W1200 x D900 x H904



## Fusion Multi Drawer Storage Unit

The Fusion Storage Drawer Unit includes 6x large drawers, 12x small drawers and lockable castors for ultimate storage.

Model: FUS006

W1200 x D900 x H904



## Fusion Wembley Display

The Fusion Wembley sits atop a storage frame to create a browser and organisation centre. Includes 20 tote boxes.

Model: FUS003

W1200 x D900 x H1172



## Fusion Bookcase

The Fusion Mobile Bookcase is perfect for reader selection and learning materials and resources.

Model: FUS004

W900 x D450 x H1230





# Storage



### Rubix Midi Browser

The Rubix Browser is ideal for fiction series books making it ideal for book storage and display. Accessible all sides.

**Model:** RUB002

**W1200 x D1200 x H1088**



### Rubixi Maxi Browser

The Rubix Browser is accessible all sides, making it ideal for fiction series book storage and display.

**Model:** RUB003

**W1200 x D1200 x H1311**



### Kube Midi Browser

The Kube Browser is ideal for large format picture books or art supplies. Accessible from all sides.

**Model:** KUB001

**W804 x D804 x H681**



### Kube Maxi Browser

The Kube Book Display is ideal for highlighting popular book collections and toys or storing Lilypad Floor Cushions.

**Model:** KUB002

**W804 x D804 x H1074**



### Rubix Book Tower

The Rubix Book Tower is ideal for highlighting popular book collections or segregation series for quick selection..

**Model:** RUB001

**W804 x D804 x H1690**



# Storage



## Inform 900 Shelving System

The Inform 900 is ideal for under windows, against walls or as a central display for primary school book collections.

Model: INF001 | INF002

W900 x D310 | 600 x H950



## Inform 1200 Shelving System

The Inform 1200 suits libraries, classrooms, staff rooms and admin spaces to house books, resources and materials.

Model: INF003 | INF004

W900 x D310 | 600 x H1250



## Inform 1500 Shelving System

The Inform 1500 with its eye level height ensures you can put your finger on exactly what you're looking for.

Model: INF005 | INF006

W900 x D310 | 600 x H1550



## Inform 1800 Shelving System

The Inform 1800 offers multiple shelves for high volume storage needs, ideal for secondary school libraries.

Model: INF007 | INF008

W900 x D310 | 600 x H1850



## Inform Aisle Shelving System

The Inform Aisle Shelving System houses large collection in a stylish bookcase format that is accessible from both sides.

Model: INF009 | INF010

W1800 x D310 | 600 x H1850









# Technical Guide

## 1/2 Height Lockers

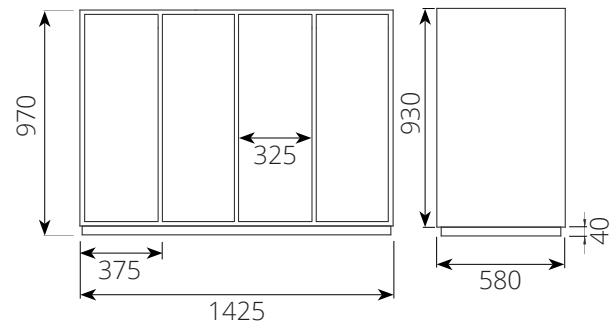

## Mobile Lockers

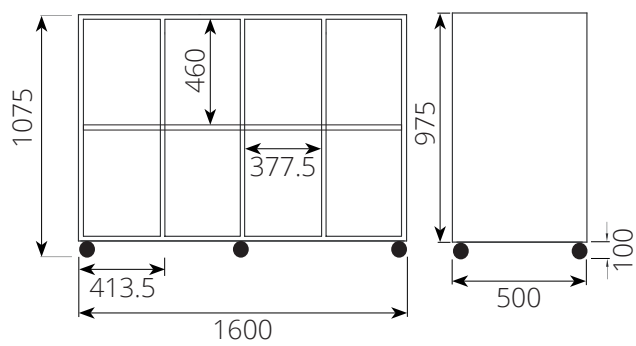

## 3/4 Height Lockers

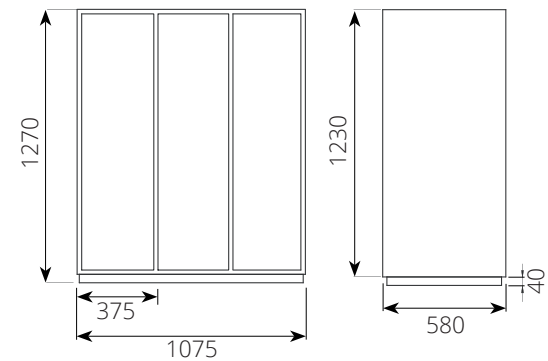

## Full Height Lockers

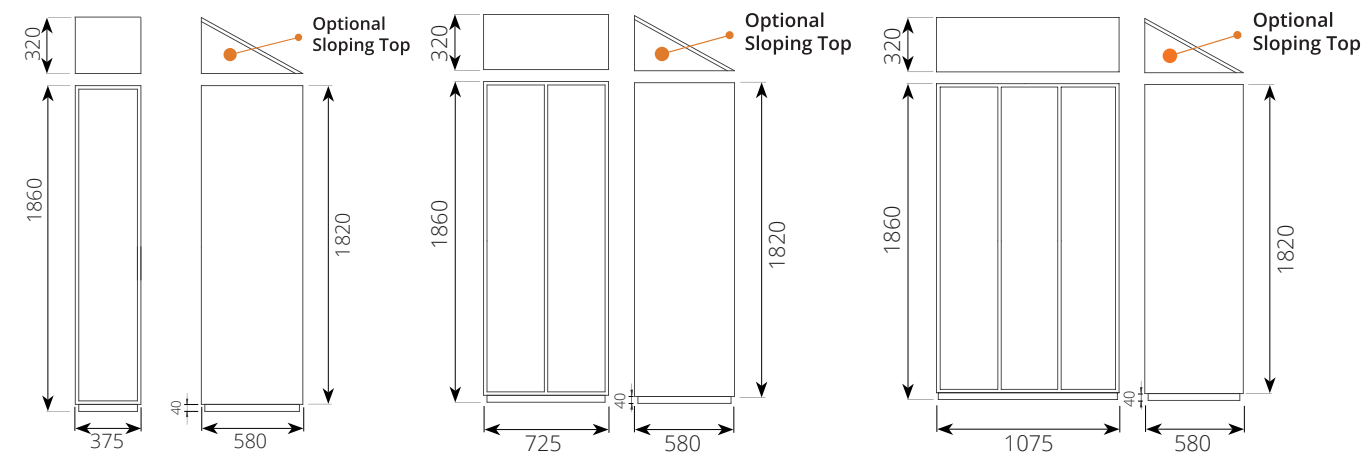

# Technical Guide

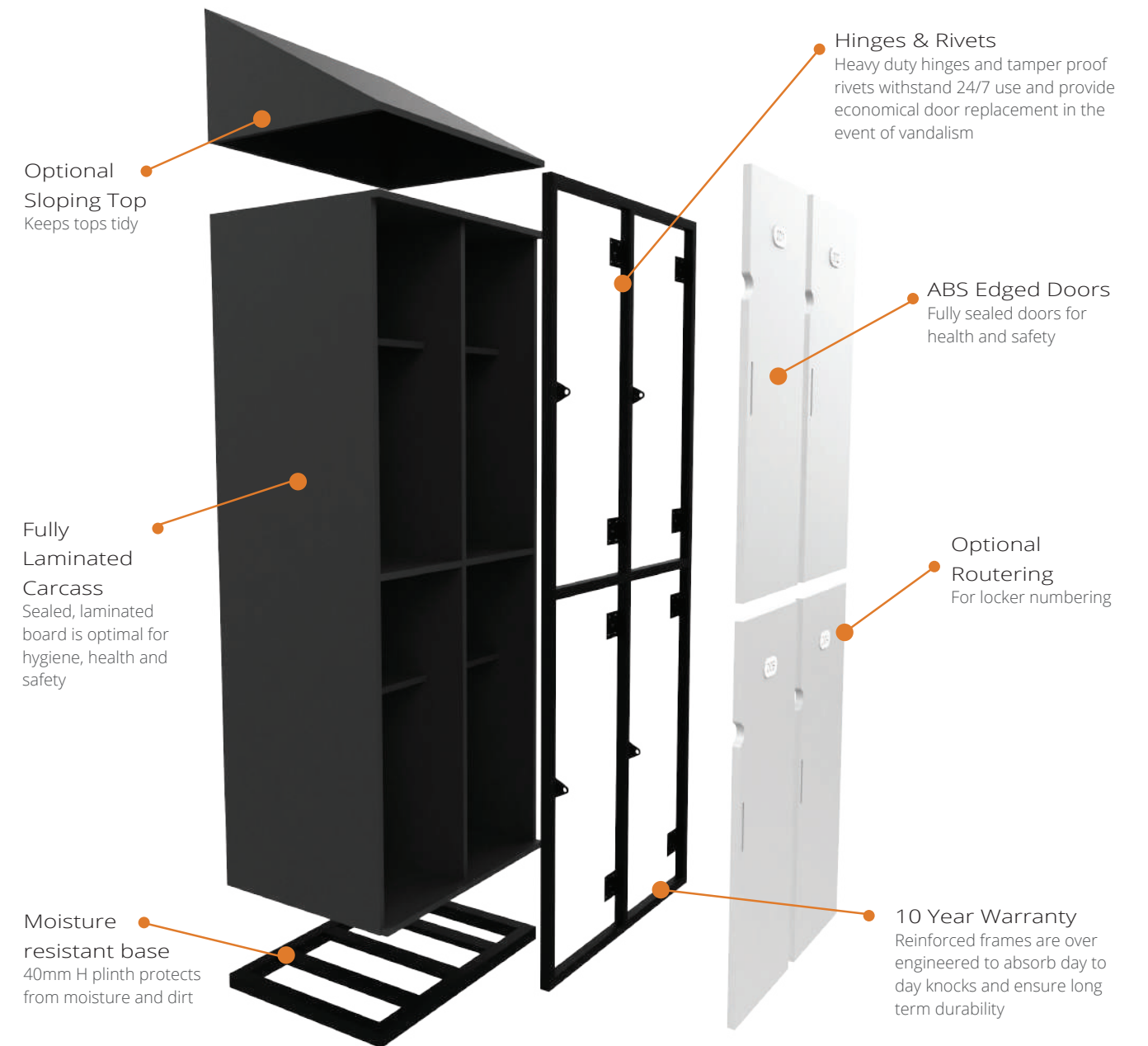

## Options

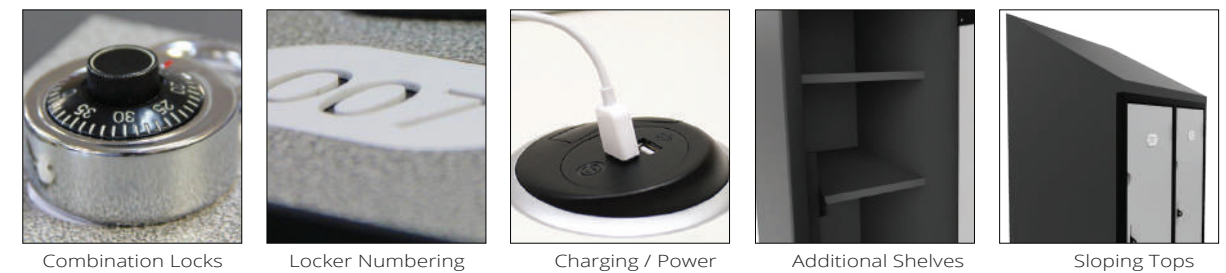



# Materials

## E0 Laminate (standard) - Secure it Doors

Reflecting the most realistic timber grains and brilliant whites and neutrals this range has been curated to complement the Black steel frame and Storm carcass on our Secure it Lockers.



E0: Natural Oak



E0: Dark Oak



E0: Storm

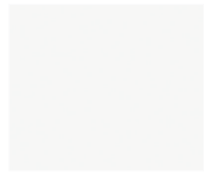

E0: White



E0: Grey



E0: Zincworks



E0: Diamond

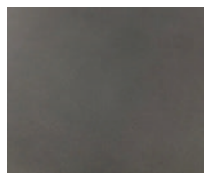

E0: Ironstone

## E0 Laminate - Secure it Doors

Offering a range of colours, including fun brights, this range has been curated to add personality and vibrancy to your Secure it Locker doors.

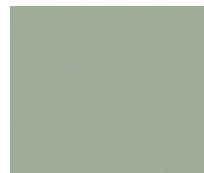

Laminex: Bayleaf



Laminex: China Blue



Laminex: Infinity

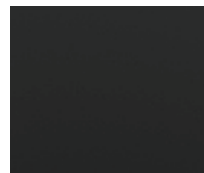

Laminex: Midnight



Laminex: Elegant Oak



Laminex: Peacock



Laminex: Juicy



Laminex: Mandarin

# Materials

## Compact Laminate - Secure it Doors

Made from layers of recycled paper fibres sandwiched between laminate, compressed under high pressure and heated to permanently meld together, compact laminate is highly resistant to marks, stains and scratching, easy to clean and maintain and is waterproof.



Compact: Milkwood



Compact: Classic Oak



Compact: Walnut

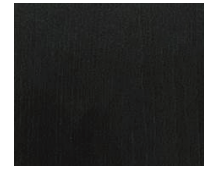

Compact: Burnished

## Naturals - Secure it Doors

Our calming Naturals range has been curated to create a warm, cosy vibe allowing users to feel comfortable and relaxed and are beautifully balanced by the contrasting Storm carcass.

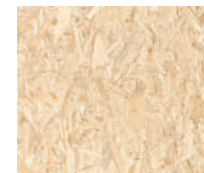

Chipboard

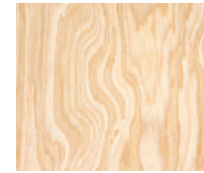

Birch Plywood



Rubberwood



## E0 Laminate - Storewell, Fusion, Kube, Rubix, Inform

Reflecting the most realistic timber grains and brilliant whites this range has been curated to complement any fabric selection. 25 mm option available upon request.

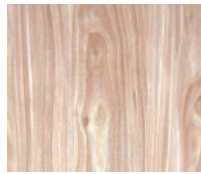

E0: Natural Oak



E0: Dark Oak



E0: Storm

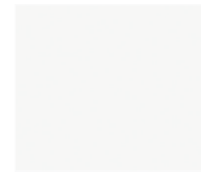

E0: White

## Laminated Plywood

Warm, soft and calming, this range has been curated to reduce stress and restore energy levels through it's biophilic properties.



Ply: Natural Oak

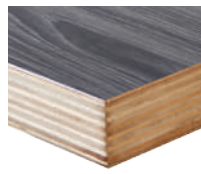

Ply: Dark Oak



Ply: White



Ply: Birch (sealed)

## Hardwood Timber

Rubberwood has been included in the range to offer a strong, durable hardwood timber that is resistant to damage and daily wear and tear. This low maintenance, highly stable recycled wood is also eco-friendly.



Rubberwood

## Shipping

Shipping is calculated at the time of order. White Glove delivery and installation is extra. For more information, visit [vef.com.au](http://vef.com.au)

## Furniture Warranty

To initiate a claim, contact a helpful VE Furniture Account Representative by emailing [info@vef.com.au](mailto:info@vef.com.au) or calling 1300 966 640, Monday-Friday 9am to 5pm AEST.

For complete warranty information please visit [vef.com.au/warranty](http://vef.com.au/warranty)

## Returns + Exchanges

To place a return, please contact an Account Representative at [info@vef.com.au](mailto:info@vef.com.au) or give us a ring on 1300 96 66 40 within 30 days of receiving your goods from VE Furniture. Our Account Representatives will happily determine if the product can be returned or exchanged. White Glove Installation fees are non-refundable.

For more details on our Terms + Conditions, please visit [vef.com.au/terms-of-service](http://vef.com.au/terms-of-service)

## Showroom + Design Centre

69- 75 Glenvale Crescent  
Mulgrave Vic 3170

## Online

[Info@vef.com.au](mailto:Info@vef.com.au)  
[www.vef.com.au](http://www.vef.com.au)

## Phone

1300 966 640



Showroom + Design Centre  
69- 75 Glenvale Crescent  
Mulgrave Vic 3170

**SHOWROOM**

Phone : 1300 966 640

**PHONE**

Info@vef.com.au  
www.vef.com.au

**ONLINE**

